

Experiment No. 1

1.0 Title:-

To perform **Direct Load test** on 3- phase Alternator at different power factors and determine the **voltage regulation**.

2.0 Prior Concepts:-

- Working principle and construction of Alternator.
- EMF equation.
- Armature reaction.
- Effect of power factor of Load on induced emf.

3.0 New Concepts:-

Proposition 1 : Effect of Load :-

When alternator is loaded its terminal voltage changes. The change in terminal voltage depends on load current and power factor of the load.

Concept Structure 1:-

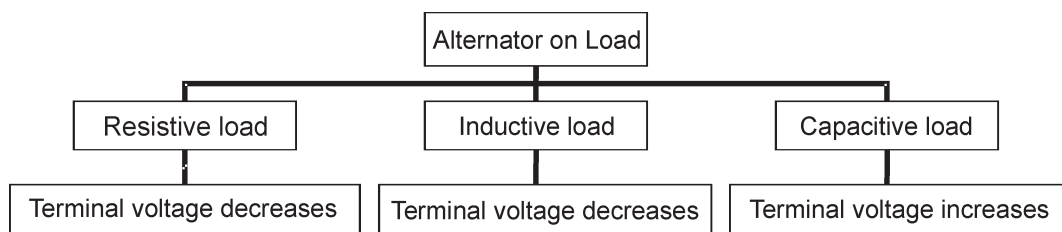

Proposition 2: Drop in Terminal Voltage:-

The factors which affects the terminal voltage are-

- armature resistance
- leakage reactance and
- armature reaction.

Concept Structure 2:-

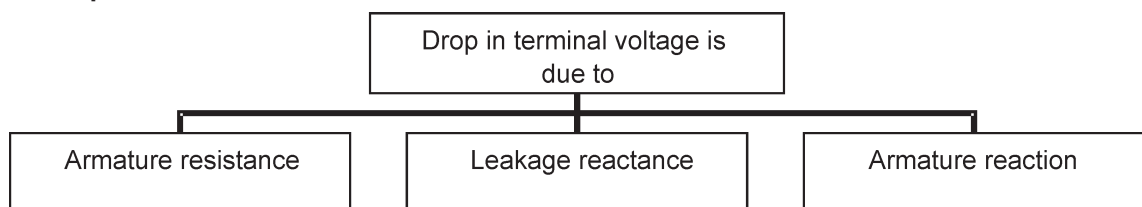

Proposition 3: Synchronous Reactance:-

The effect of reactance due to armature reaction combined with leakage reactance is called as synchronous reactance.

Proposition 4: Equivalent Circuit of an Alternator:-

The Alternator can be represented as a voltage source in series with the Armature resistance and synchronous reactance.

Concept Structure 4:-

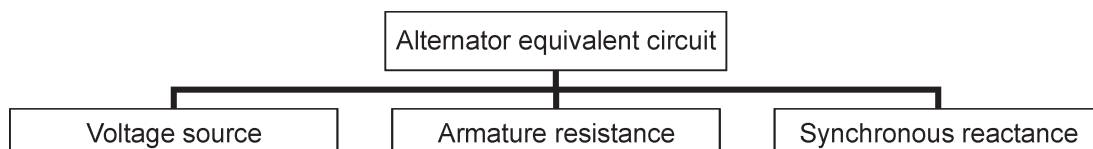

Proposition 5: Voltage Regulation:-

The percentage voltage regulation of an alternator is defined as the percentage change in voltage from no load to full load. With respect to full load voltage.

$$\text{Percentage voltage regulation} = \frac{E_o - V}{V} \times 100,$$

Where E_o is magnitude of no load voltage and V is magnitude of full load voltage.

4.0 Learning Objectives:-**4.1 Intellectual Skills:-**

- To understand necessity of excitation and methods of excitation.
- To understand the effect of speed and field current on induced emf.
- To select proper loading arrangement and instruments.
- To state the performance at different power factors.

4.2 Motor Skills:-

- To make the connections as per circuit diagram.
- To start the motor i.e. the prime mover.
- To adjust the terminal voltage of an alternator to a rated value.
- To load the alternator in steps.

5.0 Equipments :-

- Alternator coupled to D.C. motor:
Alternator - V, kVA, 3ph, 50Hz,rpm
DC Motor - HP, V, Amp,rpm
- Ammeters – (A.C.) Amps - 3 No.
(D.C.) Amps. - 1 No.
- Voltmeter- (A.C.)Volts. - 1 No.
- Three phase balanced load (Resistive, Inductive and Capacitive)
- Rheostat – (R_1)Ohm, A.
- Potential Divider – (R_2)..... Ohm, A.

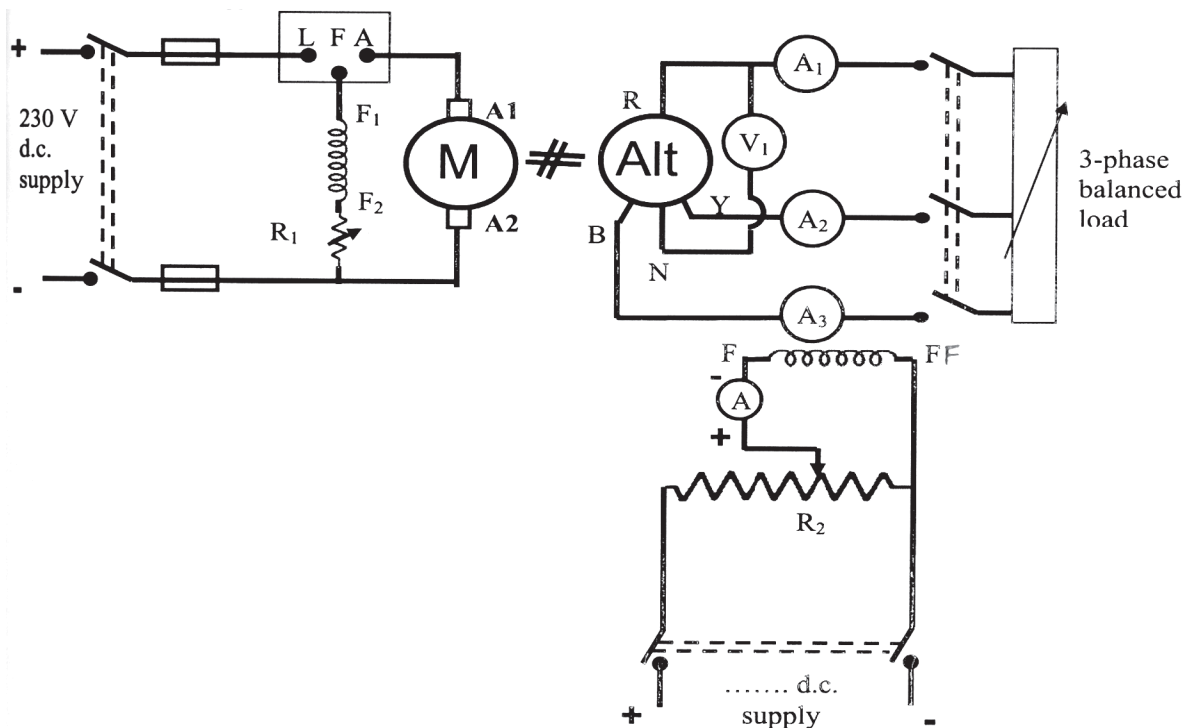
6.0 Circuit diagram :-

7.0 Stepwise Procedure:-

1. Make the connections as per circuit diagram.
2. Set its field potential divider to zero output position.
3. Set the field resistance of motor to minimum value.
4. Switch ON the DC supply for motor and start the motor with the help of starter.
5. Adjust the speed of motor to the synchronous speed of alternator with the help of the field rheostat.
6. Switch ON the supply to the potential divider and adjust the field current of alternator to such a value which gives rated terminal voltage. Note this no load voltage.
7. Load the alternator, in steps, upto rated value. Keep the speed of the set constant at each load.
8. Note the corresponding meter readings at each load condition.
9. Repeat step number 6 to 8 for different loads such as Inductive (Lagging p.f.) and Capacitive (leading p.f.) loads.

8.0 Observation Table:-

1. Speed of the set (Alternator) = rpm.
2. No-load voltage (E_o) = volts.

a) **For Resistive (Unity p.f.) load :-**

Sr. No.	Load Current (I_1) Amp	Terminal Voltage (V_1) Volts

b) **For Inductive (Lagging p.f.) load:-**

Sr. No.	Load Current (I_1) Amp	Terminal Voltage (V_1) Volts

c) **For Capacitive (Leading p.f.) load:-**

Sr. No.	Load Current (I_1) Amp	Terminal Voltage (V_1) Volts

**Dated signature of
subject teacher**

9.0 Sample Calculations :-

(Different groups should be asked to calculate voltage regulation at different load conditions)

For reading No.

A) For Resistive load:-

$$\% \text{ Voltage Regulation} = \frac{V_{no\ load} - V_{load}}{V_{load}} \times 100 = \frac{\quad}{\quad} \%$$

B) For Inductive load:-

$$\% \text{ Voltage Regulation} = \frac{V_{no\ load} - V_{load}}{V_{load}} \times 100 = \frac{\quad}{\quad} \%$$

C) For Capacitive load:-

$$\% \text{ Voltage Regulation} = \frac{V_{no\ load} - V_{load}}{V_{load}} \times 100 = \frac{\quad}{\quad} \%$$

9.0 Result / Conclusion :-

The voltage regulation of alternator at given load is found to be :-

- | | | | |
|------|-----------------|---|---|
| i) | Resistive load | - | % |
| ii) | Inductive load | - | % |
| iii) | Capacitive load | - | % |

11.0 Questions:-

(Note :- Teacher shall distribute the following questions in Three different groups)

1. What are the reasons of drop in terminal voltage when the alternator is loaded?
2. State the Load conditions at which terminal voltage rises?
3. What will be the effect of reduction in speed of DC motor when the alternator is loaded?
4. Comment on the terminal voltage of alternator under Resistive load, Inductive load and Capacitive load?
5. State the difference between regulation up and regulation down.
6. Draw the equivalent circuit for one phase of alternator.
7. Draw the phasor diagram for alternator under leading power factor load.
8. What will happen If speed of prime mover falls?
9. If synchronous motor is used as prime mover instead of D.C. Motor, what should be its number of poles?
10. The purely capacitive load on alternator is 10 Amp, at 400 volt. Calculate the real power output.

Space for answers

Remark / Grade
Date :-

Checked by